

IESNA LM-80: 2008

6000 Hours Measurement and Test Report

for

Xiamen Dacol Photoelectronics Technology Co.,Ltd

8021 Xiang'an West Road, Torch High-tech Zone(Xiang'an) Industry Area, Xiamen

Product Name:	SMD LED
Model No:	2835
Tested By:	David Zhang 
Report No.:	BTR66.181.15.0034.28
Test Initiation Date:	June 22, 2015
Revision Date:	Mar 14, 2016
Test Completion Date:	Mar 10, 2016
Reviewed By:	Steven Hsu 
Prepared By:	Best Test Service Shenzhen Co., Ltd. 1st Floor, 1st Building, Weitai Industrial Park, Yingrenshi, Shiyan, Shenzhen, Guangdong,518108 China TEL: +86-755-28236006 FAX: +86-755-23467087-811 Email: certification@bestcert.cn



Note: The test report only allows to be revised within the retention period unless further standard or the requirement was noticed. This report is for the exclusive use of BEST's Client and is provided pursuant to the agreement between BEST and its Client. BEST's responsibility and Liability are limited to the terms and conditions of the agreement. BEST assumes no liability to any party, other than to the Client in accordance with the agreement, for any loss, expense or damage occasioned by the use of this report. Only the Client is authorized to permit copying or distribution of this report and then only in its entirety. Any use of the BEST name or one of its marks for the sale or advertisement of the tested material, product or service must first be approved in writing by BEST. The observations and test results in this report are relevant only to the sample tested. This report by itself does not cover that the material, product, of service is or has ever been under a BEST certification program. National Voluntary Laboratory Accreditation Program (NVLAP) has accredited this laboratory under ISO17025: 2005 for specific laboratory activities as listed in the NVLAP directory of accredited laboratories. The results shown in this report were determined by this laboratory in accordance with its terms of accreditation. This report must not be used by the client to claim product endorsement by NVLAP, NIST or any agency of the U.S. Government.

TABLE OF CONTENTS

1 - GENERAL INFORMATION.....3
1.1 PRODUCT DESCRIPTION FOR EQUIPMENT UNDER TEST (EUT)3
1.2 OBJECTIVE4
1.3 TEST FACILITY DESCRIPTION.....4
1.4 TEST EQUIPMENT LIST4
2 – SUMMARY OF TEST RESULT5
3 - TEST METHOD.....6
4 – DATA SET 1: 55°C; 150 MA.....7
5 – DATA SET 2: 85°C; 150 MA.....10
6 – DATA SET 3: 105°C; 150 MA.....13
7 – SUMMARY16
8 – EUT PHOTOS.....18
9 –TMP19



1 - GENERAL INFORMATION

1.1 Product Description for Equipment under Test (EUT)

Applicant	:	Xiamen Dacol Photoelectronics Technology Co.,Ltd
Model Name	:	SMD LED
Model Number	:	2835
Number of LED Light Source tested	:	See tables.
Description of auxiliary Equipment	:	Labsphere 50cm 2II Integrating Sphere Labsphere CDS2100 Spectrometer Keithley 2420 Sourcemeter ESPEC PH301 Temperature Chamber
Operating Cycle	:	Constant current.
Ambient Conditions	:	LED light source are operated in environmental control chambers. The temperature of the ambient air around the LED light source is actively controlled by air flowing through the chamber. T _A : See tables; RH : < 45%; Air flow : 300 CFM
Case temperature (test point temperature)	:	See Section 11.
Drive current of the LED light source during lifetime test	:	See tables.
Initial luminous flux and forward voltage at photometric measurement current	:	See tables.
Lumen maintenance data for each individual LED light source along with median value, standard deviation, minimum and maximum lumen maintenance value for all of the LED Light sources	:	See tables.
Observation of LED light source failures including the failure conditions and time of failure.	:	See tables.
LED light source monitoring interval	:	The LED light sources are inspected at regular intervals (24 hours) throughout the 6000 hours test.
Photometric measurement uncertainty	:	+/- 1.5% on flux measurements for LM- 80 testing.
Chromaticity shift reported over the Measurement time	:	See tables.
Stabilization Time	:	0.75 hours
LED Light Source Test interval	:	At regular intervals (1000 hours) throughout the 6000 hours test.
Date of Receiving Sample	:	June 22, 2015
Test Duration	:	June 22, 2015 to Mar 10, 2016

1.2 Objective

The following test report is prepared on behalf of Xiamen Dacol Photoelectronics Technology Co.,Ltd in accordance with IESNA LM-80-08, used the following American National Standards or illumination Engineering Society of North America test guides:

Measurement of LEDs (2nd ed.), CIE 127:2007; IESNA Testing Procedures Committee. IESNA LM-79-2008 Approved Method for the Electrical and Photometric Measurements of LED Light Sources, New York: Illuminating Engineering Society of North America, 2008.

ASSIST Recommends: LED Life Testing. Vol. 1-6, 2005. Lighting Research Center, Rensselaer Polytechnic Institute, Troy, NY, 2005.

ANSI/IESNA Testing Procedures Committee, IESNA RP-16-07, Nomenclature and Definitions for Illuminating Engineering. See also Addendum A on solid-state lighting (Document is now continuously updated)

IESNA Testing Procedures Committee, IESNA LM-40-01, Approved Method for Life Performance Testing of Fluorescent Lamps, New York: Illuminating Engineering Society of North America, 2001.

1.3 Test Facility Description

The Energy Efficiency Lab used by BEST to collect energy efficiency measurement data is located in 1st Floor, 1st Building, Weitai Industrial Park, Yingrenshi, Shiyao, Baoan, Shenzhen, China. BEST Test Service Shenzhen Co., Ltd is a EPA recognized lab for lighting products, BEST is a National Institute of Standards and Technology (NIST) accredited laboratory, under the National Voluntary Laboratory Accredited Program (Lab Code 200770-0). BEST Test Service Shenzhen Co., Ltd is also an ELI accredited lab for lighting products (ELI Certificate No. ELI-L04-2010) and UL accredited lab for lighting products

1.4 Test Equipment List

Apparatus List	Device	Cal. Date	Cal Due Date
1	Integral Sphere+ Spectroradiometer	Calibrated before Test	
2	Standard Light Source	Mar 10, 2016	Mar 09, 2017
3	Source Meter	Oct 18, 2015	Oct 17, 2016
4	Temperature Chamber	Sep 17, 2015	Sep 16, 2016
5	Multi Channel LED Aging Source	Sep 17, 2015	Sep 16, 2016
6	6 ^{1/2} Digital Multimeter	Mar 28, 2015	Mar 27, 2016
7	Temperature Controller	Oct 18, 2015	Oct 17, 2016
8	Second Meter	Oct 18, 2015	Oct 17, 2016

Statement of Traceability: BEST Test Service Shenzhen Co., Ltd. certifies that all calibration has been performed using suitable standards traceable to the NIM China.

2 – Summary of Test Result

Data Set	Case Temperature(Ts) ℃	Ambient Temperature(Ta) ℃	Drive Current(mA)	Average Lumen Maintenance at 6,000 hours	Average Chromaticity Shift ($\Delta u'v'$) at 6,000 hours
1	55	55±2	150.0	97.2%	0.0028
2	85	85±2	150.0	96.3%	0.0028
3	100	100±2	150.0	94.3%	0.0036



3 - Test Method

3.1 Photometric and Electrical Measurement

Total light output (luminous flux) for the $25^{\circ}\text{C} \pm 1^{\circ}\text{C}$ ambient temperature conditions is measured using a Labsphere 50cm 2 Π geometry integrating sphere. Temperature is controlled and measured at manufacture defined TMP inside the sphere. Spectral radiant flux measurements are made using Labsphere CDS 2100 to the detector port of the integrating sphere. Each LED package is operated at rated drive current (CC Mode). Each package should be stable before measurements are made. The determining method of stable is as follows:

Step 1 Take 3 measurements of the lamp light output at 15 minute interval (total time=30mintues.)This time period is in addition to the recommended pre-burning time.

Step 2 Calculate the percent difference between the maximum measured value and the minimum measured value for the three consecutive measurements.

Step 3 if the value calculated in Step 2 does not exceed 0.5 percent, the lamp is considered stable.

Luminous flux, chromaticity coordinates, correlated color temperature and color rendering index for each lamp are calculated from the spectral radiant flux measurements taken at 2 nm intervals over the range 350 to 1050 nm. The calibration of the sphere photometer-spectrometer system is traceable to the NIST USA. The EUT fed under CC mode at rated input by KEITHLEY 2420 power source.

The total uncertainty of the light output measurements is estimated, at the 95% confidence level, not to exceed $\pm 1.6\%$ over the wavelength range 350-1050 nm.

3.2 Season the LED light source from 0 hour to 6000 hours

Three ESPEC Temperature Chambers are using for Season, and the temperature is set to 55°C , 85°C , 105°C , the airflow is minimum to keep the uniformity of temperature.LED light source are operated steady state (no cycling) for a period of 6000 hours, checked the lumen flux and Chromaticity Shift every 1000 hours. The samples are inspected at regular intervals (12 hours) throughout the 6000hours. The time and date of failure of each lamp is recorded. The actual elapsed time for each light source is in hour.

4 – Data Set 1: 55°C; 150 mA

Description of Light Sources tested	:	2835
Case Temperature	:	55°C
Ambient Temperature	:	55°C
Drive Current	:	150 mA
Measure Current	:	150 mA
Failures Observed	:	None

INITIAL DATA								
Sample No.	Ref.Voltage (V)	Forward Current (mA)	Luminous Flux (Lumens)	CCT (K)	x (CIE 1931)	y (CIE 1931)	u' (CIE 1976)	v' (CIE 1976)
L1	6.41	150	103.62	3465	0.4089	0.3960	0.2359	0.5140
L2	6.47	150	102.65	3430	0.4120	0.3997	0.2364	0.5159
L3	6.50	150	104.52	3418	0.4106	0.3947	0.2375	0.5137
L4	6.49	150	103.62	3454	0.4097	0.3966	0.2361	0.5143
L5	6.40	150	104.85	3440	0.4098	0.3953	0.2368	0.5138
L6	6.43	150	102.56	3437	0.4109	0.3977	0.2365	0.5150
L7	6.43	150	103.95	3469	0.4071	0.3918	0.2364	0.5120
L8	6.47	150	101.52	3422	0.4106	0.3951	0.2373	0.5138
L9	6.41	150	100.56	3459	0.4092	0.3958	0.2361	0.5139
L10	6.43	150	102.95	3477	0.4084	0.3962	0.2355	0.5140
L11	6.50	150	103.86	3411	0.4109	0.3946	0.2378	0.5137
L12	6.50	150	102.52	3431	0.4102	0.3952	0.2371	0.5138
L13	6.41	150	104.78	3429	0.4108	0.3965	0.2369	0.5145
L14	6.50	150	104.35	3472	0.4071	0.3922	0.2363	0.5121
L15	6.50	150	102.56	3438	0.4111	0.3983	0.2363	0.5152
L16	6.47	150	103.92	3468	0.4084	0.3950	0.2360	0.5135
L17	6.40	150	104.20	3433	0.4109	0.3972	0.2367	0.5148
L18	6.50	150	103.20	3464	0.4082	0.3940	0.2363	0.5131
L19	6.41	150	103.92	3419	0.4109	0.3954	0.2374	0.5140
L20	6.48	150	104.28	3491	0.4065	0.3929	0.2356	0.5123
L21	6.43	150	104.65	3430	0.4104	0.3956	0.2370	0.5140
L22	6.41	150	103.90	3475	0.4082	0.3953	0.2357	0.5136
L23	6.49	150	100.56	3456	0.4089	0.3949	0.2363	0.5135
L24	6.40	150	101.59	3428	0.4090	0.3918	0.2377	0.5122
L25	6.51	150	102.53	3456	0.4087	0.3944	0.2364	0.5133
AV	6.45	150.0	103.26	3447	0.4095	0.3953	0.2366	0.5138
MIN	6.40	150.0	100.56	3411	0.4065	0.3918	0.2355	0.5120
MAX	6.51	150.0	104.85	3491	0.4120	0.3997	0.2378	0.5159
STDEV	0.04	0.0	1.24	22	0.0014	0.0019	0.0006	0.0009
N	25	25	25	25	25	25	25	25

Description of Light Sources tested	:	2835
Case Temperature	:	55°C
Ambient Temperature	:	55°C
Drive Current	:	150 mA
Measure Current	:	150 mA
Failures Observed	:	None

LUMEN MAINTENANCE							
Sample No.	0H	1000H	2000H	3000H	4000H	5000H	6000H
L1	100.0%	99.7%	99.2%	98.8%	98.1%	97.6%	96.8%
L2	100.0%	99.8%	99.3%	98.9%	98.3%	97.8%	97.5%
L3	100.0%	99.7%	99.2%	98.8%	98.3%	97.7%	97.0%
L4	100.0%	100.0%	99.5%	99.1%	98.6%	98.0%	97.7%
L5	100.0%	99.7%	99.2%	98.8%	98.3%	97.8%	97.1%
L6	100.0%	99.7%	99.2%	98.8%	98.2%	97.7%	97.1%
L7	100.0%	99.9%	99.4%	98.9%	98.4%	97.9%	97.6%
L8	100.0%	100.0%	99.5%	99.0%	98.5%	98.0%	97.6%
L9	100.0%	99.6%	99.1%	98.6%	98.1%	97.6%	97.2%
L10	100.0%	99.8%	98.3%	97.9%	97.3%	96.8%	96.7%
L11	100.0%	99.9%	99.4%	99.0%	98.5%	97.9%	97.6%
L12	100.0%	99.6%	99.1%	98.7%	98.2%	97.6%	97.3%
L13	100.0%	99.8%	99.4%	98.9%	98.4%	97.9%	96.6%
L14	100.0%	100.0%	99.5%	99.1%	98.6%	98.0%	96.6%
L15	100.0%	99.8%	99.3%	98.9%	98.4%	97.8%	97.5%
L16	100.0%	99.6%	99.1%	98.7%	98.2%	97.6%	97.3%
L17	100.0%	100.1%	99.6%	99.2%	98.6%	98.1%	97.8%
L18	100.0%	100.0%	99.5%	99.1%	98.5%	98.0%	97.7%
L19	100.0%	100.0%	99.5%	99.1%	98.6%	98.0%	96.6%
L20	100.0%	99.6%	99.1%	98.7%	98.2%	97.7%	97.3%
L21	100.0%	99.9%	99.4%	99.0%	97.5%	97.0%	96.7%
L22	100.0%	99.6%	99.1%	98.7%	98.3%	97.7%	97.4%
L23	100.0%	99.8%	99.3%	98.9%	98.3%	97.8%	96.8%
L24	100.0%	99.9%	99.4%	99.0%	98.5%	97.9%	97.6%
L25	100.0%	100.1%	99.6%	99.1%	98.6%	98.1%	96.7%
AV	100.0%	99.8%	99.3%	98.9%	98.3%	97.8%	97.2%
MIN	100.0%	99.6%	98.3%	97.9%	97.3%	96.8%	96.6%
MAX	100.0%	100.1%	99.6%	99.2%	98.6%	98.1%	97.8%
STDEV	0.0%	0.2%	0.3%	0.3%	0.3%	0.3%	0.4%
N	25	25	25	25	25	25	25

Description of Light Sources tested	:	2835
Case Temperature	:	55°C
Ambient Temperature	:	55°C
Drive Current	:	150 mA
Measure Current	:	150 mA
Failures Observed	:	None

Δu'v'							
Sample No.	0H	1000H	2000H	3000H	4000H	5000H	6000H
L1	0.0000	0.0009	0.0014	0.0018	0.0021	0.0024	0.0028
L2	0.0000	0.0010	0.0015	0.0019	0.0022	0.0025	0.0028
L3	0.0000	0.0007	0.0012	0.0016	0.0019	0.0022	0.0025
L4	0.0000	0.0008	0.0013	0.0017	0.0021	0.0023	0.0027
L5	0.0000	0.0007	0.0012	0.0016	0.0019	0.0022	0.0025
L6	0.0000	0.0012	0.0017	0.0021	0.0024	0.0027	0.0030
L7	0.0000	0.0008	0.0013	0.0016	0.0020	0.0023	0.0026
L8	0.0000	0.0008	0.0013	0.0017	0.0021	0.0023	0.0027
L9	0.0000	0.0008	0.0013	0.0017	0.0021	0.0023	0.0027
L10	0.0000	0.0009	0.0014	0.0018	0.0021	0.0024	0.0027
L11	0.0000	0.0009	0.0014	0.0018	0.0021	0.0024	0.0028
L12	0.0000	0.0008	0.0013	0.0016	0.0020	0.0023	0.0026
L13	0.0000	0.0014	0.0019	0.0023	0.0026	0.0029	0.0033
L14	0.0000	0.0009	0.0014	0.0018	0.0021	0.0024	0.0028
L15	0.0000	0.0009	0.0014	0.0018	0.0021	0.0024	0.0027
L16	0.0000	0.0014	0.0019	0.0023	0.0026	0.0029	0.0033
L17	0.0000	0.0008	0.0013	0.0016	0.0020	0.0023	0.0026
L18	0.0000	0.0009	0.0013	0.0017	0.0021	0.0023	0.0027
L19	0.0000	0.0009	0.0014	0.0018	0.0021	0.0024	0.0028
L20	0.0000	0.0008	0.0013	0.0016	0.0019	0.0022	0.0026
L21	0.0000	0.0012	0.0017	0.0021	0.0024	0.0026	0.0030
L22	0.0000	0.0013	0.0017	0.0021	0.0024	0.0027	0.0031
L23	0.0000	0.0007	0.0012	0.0016	0.0019	0.0022	0.0025
L24	0.0000	0.0007	0.0012	0.0015	0.0019	0.0021	0.0025
L25	0.0000	0.0007	0.0012	0.0016	0.0019	0.0022	0.0025
AV	0.0000	0.0009	0.0014	0.0018	0.0021	0.0024	0.0028
MIN	0.0000	0.0007	0.0012	0.0015	0.0019	0.0021	0.0025
MAX	0.0000	0.0014	0.0019	0.0023	0.0026	0.0029	0.0033
STDEV	0.0000	0.0002	0.0002	0.0002	0.0002	0.0002	0.0002
N	25	25	25	25	25	25	25

5 – Data Set 2: 85°C; 150 mA

Description of Light Sources tested	:	2835
Case Temperature	:	85°C
Ambient Temperature	:	85°C
Drive Current	:	150 mA
Measure Current	:	150 mA
Failures Observed	:	None

INITIAL DATA								
Sample No.	Ref. Voltage (V)	Forward Current (mA)	Luminous Flux (Lumens)	CCT (K)	x (CIE 1931)	y (CIE 1931)	u' (CIE 1976)	v' (CIE 1976)
L26	6.53	150	102.39	3410	0.4121	0.3974	0.2374	0.5150
L27	6.49	150	104.52	3409	0.4111	0.3946	0.2378	0.5137
L28	6.41	150	101.25	3416	0.4114	0.3965	0.2373	0.5146
L29	6.51	150	103.58	3435	0.4111	0.3979	0.2365	0.5151
L30	6.40	150	104.82	3443	0.4096	0.3949	0.2368	0.5136
L31	6.52	150	102.35	3424	0.4120	0.3988	0.2367	0.5156
L32	6.42	150	100.86	3414	0.4113	0.3959	0.2375	0.5143
L33	6.50	150	101.56	3437	0.4107	0.3972	0.2366	0.5147
L34	6.51	150	102.85	3447	0.4091	0.3943	0.2367	0.5133
L35	6.42	150	104.79	3444	0.4096	0.3951	0.2367	0.5137
L36	6.40	150	103.62	3433	0.4103	0.3956	0.2370	0.5140
L37	6.40	150	104.29	3421	0.4098	0.3929	0.2377	0.5128
L38	6.40	150	101.25	3430	0.4094	0.3931	0.2374	0.5129
L39	6.41	150	100.75	3422	0.4103	0.3943	0.2375	0.5135
L40	6.40	150	102.53	3423	0.4112	0.3967	0.2371	0.5146
L41	6.41	150	104.28	3469	0.4073	0.3921	0.2364	0.5121
L42	6.46	150	104.75	3433	0.4108	0.3971	0.2367	0.5147
L43	6.53	150	103.62	3425	0.4122	0.3995	0.2366	0.5159
L44	6.48	150	102.59	3464	0.4084	0.3945	0.2362	0.5133
L45	6.47	150	104.25	3421	0.4121	0.3988	0.2368	0.5156
L46	6.52	150	100.85	3428	0.4108	0.3962	0.2370	0.5144
L47	6.52	150	101.38	3448	0.4089	0.3938	0.2367	0.5131
L48	6.53	150	102.59	3442	0.4099	0.3958	0.2366	0.5141
L49	6.41	150	103.62	3472	0.4076	0.3934	0.2361	0.5127
L50	6.54	150	104.27	3452	0.4098	0.3966	0.2362	0.5144
AV	6.46	150.0	102.94	3434	0.4103	0.3957	0.2369	0.5141
MIN	6.40	150.0	100.75	3409	0.4073	0.3921	0.2361	0.5121
MAX	6.54	150.0	104.82	3472	0.4122	0.3995	0.2378	0.5159
STDEV	0.05	0.0	1.39	17	0.0013	0.0020	0.0005	0.0010
N	25	25	25	25	25	25	25	25

Description of Light Sources tested	:	2835
Case Temperature	:	85°C
Ambient Temperature	:	85°C
Drive Current	:	150 mA
Measure Current	:	150 mA
Failures Observed	:	None

LUMEN MAINTENANCE							
Sample No.	0H	1000H	2000H	3000H	4000H	5000H	6000H
L26	100.0%	99.7%	99.2%	98.7%	97.9%	97.3%	96.5%
L27	100.0%	99.7%	99.4%	98.9%	98.1%	97.5%	97.2%
L28	100.0%	99.8%	99.5%	99.0%	98.2%	97.6%	95.9%
L29	100.0%	98.7%	98.3%	97.8%	97.1%	96.5%	95.6%
L30	100.0%	99.8%	99.5%	99.0%	98.3%	97.7%	96.9%
L31	100.0%	99.9%	99.5%	99.0%	98.2%	97.6%	96.8%
L32	100.0%	99.9%	99.3%	98.7%	98.0%	97.3%	96.5%
L33	100.0%	99.6%	99.0%	98.5%	97.8%	97.1%	96.3%
L34	100.0%	99.8%	99.3%	98.8%	98.0%	97.4%	96.5%
L35	100.0%	99.6%	99.1%	98.6%	97.8%	97.2%	96.1%
L36	100.0%	100.1%	99.6%	99.7%	98.9%	98.3%	95.7%
L37	100.0%	99.6%	99.1%	98.6%	97.8%	97.2%	96.0%
L38	100.0%	99.7%	99.2%	98.7%	97.9%	97.3%	96.5%
L39	100.0%	99.6%	99.0%	98.5%	97.7%	97.1%	96.2%
L40	100.0%	99.8%	99.3%	98.8%	98.0%	97.4%	96.6%
L41	100.0%	99.7%	99.2%	98.7%	97.9%	97.3%	96.5%
L42	100.0%	99.5%	99.0%	98.5%	97.8%	97.2%	95.3%
L43	100.0%	100.0%	99.5%	99.0%	98.2%	97.6%	96.8%
L44	100.0%	99.6%	98.8%	98.2%	97.5%	96.9%	96.0%
L45	100.0%	99.8%	99.3%	98.7%	98.0%	97.4%	96.6%
L46	100.0%	99.8%	99.3%	98.7%	98.0%	97.3%	96.5%
L47	100.0%	99.7%	99.2%	98.7%	97.9%	97.3%	96.5%
L48	100.0%	100.7%	100.1%	99.6%	98.9%	98.3%	96.8%
L49	100.0%	99.7%	99.2%	98.7%	98.0%	97.4%	96.5%
L50	100.0%	99.6%	99.1%	98.6%	97.8%	97.2%	95.7%
AV	100.0%	99.7%	99.2%	98.8%	98.0%	97.4%	96.3%
MIN	100.0%	98.7%	98.3%	97.8%	97.1%	96.5%	95.3%
MAX	100.0%	100.7%	100.1%	99.7%	98.9%	98.3%	97.2%
STDEV	0.0%	0.3%	0.3%	0.4%	0.4%	0.4%	0.4%
N	25	25	25	25	25	25	25

Description of Light Sources tested	:	2835
Case Temperature	:	85°C
Ambient Temperature	:	85°C
Drive Current	:	150 mA
Measure Current	:	150 mA
Failures Observed	:	None

Δu'v'							
Sample No.	0H	1000H	2000H	3000H	4000H	5000H	6000H
L26	0.0000	0.0010	0.0012	0.0019	0.0024	0.0027	0.0030
L27	0.0000	0.0009	0.0014	0.0021	0.0026	0.0030	0.0033
L28	0.0000	0.0008	0.0012	0.0016	0.0020	0.0025	0.0027
L29	0.0000	0.0003	0.0007	0.0012	0.0017	0.0021	0.0024
L30	0.0000	0.0009	0.0014	0.0021	0.0026	0.0030	0.0033
L31	0.0000	0.0007	0.0013	0.0019	0.0023	0.0028	0.0031
L32	0.0000	0.0009	0.0009	0.0015	0.0020	0.0023	0.0025
L33	0.0000	0.0008	0.0013	0.0019	0.0024	0.0028	0.0031
L34	0.0000	0.0008	0.0014	0.0019	0.0024	0.0029	0.0031
L35	0.0000	0.0004	0.0005	0.0012	0.0017	0.0021	0.0024
L36	0.0000	0.0006	0.0011	0.0016	0.0021	0.0025	0.0028
L37	0.0000	0.0005	0.0009	0.0016	0.0021	0.0025	0.0028
L38	0.0000	0.0007	0.0009	0.0016	0.0021	0.0024	0.0027
L39	0.0000	0.0009	0.0008	0.0015	0.0020	0.0024	0.0027
L40	0.0000	0.0005	0.0010	0.0017	0.0022	0.0026	0.0028
L41	0.0000	0.0012	0.0015	0.0022	0.0027	0.0030	0.0033
L42	0.0000	0.0009	0.0014	0.0021	0.0026	0.0030	0.0033
L43	0.0000	0.0011	0.0011	0.0010	0.0013	0.0017	0.0020
L44	0.0000	0.0011	0.0017	0.0022	0.0027	0.0031	0.0034
L45	0.0000	0.0009	0.0011	0.0017	0.0022	0.0026	0.0029
L46	0.0000	0.0012	0.0017	0.0022	0.0026	0.0030	0.0033
L47	0.0000	0.0009	0.0010	0.0016	0.0021	0.0024	0.0027
L48	0.0000	0.0002	0.0007	0.0013	0.0018	0.0022	0.0025
L49	0.0000	0.0003	0.0007	0.0012	0.0017	0.0021	0.0024
L50	0.0000	0.0009	0.0012	0.0015	0.0019	0.0024	0.0026
AV	0.0000	0.0008	0.0011	0.0017	0.0022	0.0026	0.0028
MIN	0.0000	0.0002	0.0005	0.0010	0.0013	0.0017	0.0020
MAX	0.0000	0.0012	0.0017	0.0022	0.0027	0.0031	0.0034
STDEV	0.0000	0.0003	0.0003	0.0003	0.0004	0.0004	0.0004
N	25	25	25	25	25	25	25

6 – Data Set 3: 105°C ; 150 mA

Description of Light Sources tested	:	2835
Case Temperature	:	105°C
Ambient Temperature	:	105°C
Drive Current	:	150 mA
Measure Current	:	150 mA
Failures Observed	:	None

INITIAL DATA								
Sample No.	Ref.Voltage (V)	Forward Current (mA)	Luminous Flux (Lumens)	CCT (K)	u' (CIE 1976)	x (CIE 1931)	y (CIE 1931)	u' (CIE 1976)
L51	6.37	150	104.62	3479	0.4078	0.3947	0.2357	0.5133
L52	6.46	150	103.28	3464	0.4096	0.3977	0.2357	0.5148
L53	6.52	150	101.28	3430	0.4107	0.3962	0.2369	0.5143
L54	6.45	150	100.59	3414	0.4120	0.3978	0.2372	0.5152
L55	6.42	150	103.65	3446	0.4105	0.3978	0.2362	0.5149
L56	6.48	150	104.25	3416	0.4112	0.3958	0.2374	0.5143
L57	6.41	150	105.00	3474	0.4077	0.3937	0.2360	0.5129
L58	6.43	150	102.38	3442	0.4085	0.3920	0.2373	0.5123
L59	6.51	150	103.59	3465	0.4092	0.3969	0.2357	0.5144
L60	6.50	150	104.75	3470	0.4090	0.3967	0.2356	0.5143
L61	6.51	150	102.52	3449	0.4108	0.3988	0.2359	0.5154
L62	6.43	150	101.29	3446	0.4102	0.3968	0.2363	0.5145
L63	6.45	150	103.52	3427	0.4117	0.3984	0.2367	0.5154
L64	6.54	150	102.53	3423	0.4113	0.3971	0.2370	0.5148
L65	6.42	150	104.59	3436	0.4098	0.3948	0.2370	0.5136
L66	6.44	150	103.92	3431	0.4114	0.3982	0.2366	0.5152
L67	6.49	150	105.00	3447	0.4081	0.3915	0.2372	0.5120
L68	6.43	150	104.28	3480	0.4071	0.3930	0.2359	0.5125
L69	6.45	150	102.75	3416	0.4131	0.4007	0.2367	0.5165
L70	6.54	150	103.62	3431	0.4113	0.3980	0.2366	0.5152
L71	6.42	150	100.52	3434	0.4105	0.3963	0.2368	0.5143
L72	6.51	150	101.59	3436	0.4109	0.3975	0.2365	0.5149
L73	6.45	150	101.65	3436	0.4111	0.3980	0.2365	0.5151
L74	6.44	150	103.85	3423	0.4099	0.3934	0.2376	0.5130
L75	6.49	150	102.78	3338	0.4179	0.4031	0.2388	0.5182
AV	6.46	150.0	103.11	3438	0.4105	0.3966	0.2366	0.5145
MIN	6.37	150.0	100.52	3338	0.4071	0.3915	0.2356	0.5120
MAX	6.54	150.0	105.00	3480	0.4179	0.4031	0.2388	0.5182
STDEV	0.04	0.0	1.37	29	0.0021	0.0026	0.0007	0.0014
N	25	25	25	25	25	25	25	25

Description of Light Sources tested	:	2835
Case Temperature	:	105°C
Ambient Temperature	:	105°C
Drive Current	:	150 mA
Measure Current	:	150 mA
Failures Observed	:	None

LUMEN MAINTENANCE							
Sample No.	0H	1000H	2000H	3000H	4000H	5000H	6000H
L51	100.0%	99.5%	98.5%	97.3%	96.3%	95.1%	94.2%
L52	100.0%	99.6%	98.5%	97.5%	96.5%	95.7%	94.8%
L53	100.0%	99.5%	98.4%	97.3%	96.3%	95.1%	94.2%
L54	100.0%	99.5%	98.5%	97.2%	96.2%	95.0%	94.1%
L55	100.0%	99.4%	98.4%	97.3%	96.3%	95.1%	94.2%
L56	100.0%	99.5%	98.5%	97.1%	96.1%	94.9%	94.0%
L57	100.0%	99.5%	98.5%	97.5%	96.5%	95.6%	94.7%
L58	100.0%	99.4%	98.3%	97.2%	96.2%	95.0%	94.1%
L59	100.0%	99.7%	98.7%	97.6%	96.6%	95.4%	94.5%
L60	100.0%	99.5%	98.5%	97.2%	96.3%	95.1%	94.2%
L61	100.0%	99.5%	98.5%	97.2%	96.2%	95.0%	94.1%
L62	100.0%	99.5%	98.5%	97.1%	96.1%	94.9%	94.0%
L63	100.0%	99.5%	98.5%	97.1%	96.2%	94.9%	94.1%
L64	100.0%	99.6%	98.5%	97.5%	96.5%	95.2%	94.3%
L65	100.0%	99.7%	98.7%	97.6%	96.6%	95.4%	94.6%
L66	100.0%	99.7%	98.7%	97.6%	96.6%	95.4%	94.6%
L67	100.0%	99.5%	98.5%	97.5%	96.5%	95.3%	94.4%
L68	100.0%	99.5%	98.5%	97.2%	96.2%	95.0%	94.1%
L69	100.0%	99.4%	98.4%	97.3%	96.3%	95.1%	94.2%
L70	100.0%	99.6%	98.6%	97.5%	96.6%	95.4%	94.5%
L71	100.0%	99.5%	98.4%	97.3%	96.3%	95.1%	94.2%
L72	100.0%	99.7%	98.6%	97.5%	96.5%	95.3%	94.4%
L73	100.0%	99.5%	98.5%	96.0%	95.1%	94.2%	93.3%
L74	100.0%	99.6%	98.5%	97.5%	96.5%	95.5%	94.7%
L75	100.0%	99.6%	98.6%	97.5%	96.5%	95.5%	94.6%
AV	100.0%	99.5%	98.5%	97.3%	96.3%	95.2%	94.3%
MIN	100.0%	99.4%	98.3%	96.0%	95.1%	94.2%	93.3%
MAX	100.0%	99.7%	98.7%	97.6%	96.6%	95.7%	94.8%
STDEV	0.0%	0.1%	0.1%	0.3%	0.3%	0.3%	0.3%
N	25	25	25	25	25	25	25

Description of Light Sources tested	:	2835
Case Temperature	:	105°C
Ambient Temperature	:	105°C
Drive Current	:	150 mA
Measure Current	:	150 mA
Failures Observed	:	None

Δu'v'							
Sample No.	0H	1000H	2000H	3000H	4000H	5000H	6000H
L51	0.0000	0.0017	0.0021	0.0029	0.0033	0.0038	0.0042
L52	0.0000	0.0014	0.0019	0.0026	0.0030	0.0035	0.0040
L53	0.0000	0.0011	0.0014	0.0021	0.0024	0.0030	0.0034
L54	0.0000	0.0012	0.0017	0.0025	0.0028	0.0034	0.0038
L55	0.0000	0.0013	0.0014	0.0019	0.0022	0.0028	0.0032
L56	0.0000	0.0015	0.0019	0.0026	0.0030	0.0034	0.0038
L57	0.0000	0.0011	0.0016	0.0024	0.0028	0.0033	0.0037
L58	0.0000	0.0006	0.0010	0.0018	0.0021	0.0027	0.0031
L59	0.0000	0.0012	0.0012	0.0016	0.0018	0.0024	0.0028
L60	0.0000	0.0009	0.0011	0.0017	0.0020	0.0026	0.0030
L61	0.0000	0.0013	0.0016	0.0023	0.0026	0.0032	0.0036
L62	0.0000	0.0014	0.0014	0.0016	0.0018	0.0023	0.0027
L63	0.0000	0.0013	0.0017	0.0025	0.0029	0.0034	0.0038
L64	0.0000	0.0013	0.0018	0.0026	0.0029	0.0035	0.0039
L65	0.0000	0.0015	0.0020	0.0027	0.0030	0.0035	0.0039
L66	0.0000	0.0012	0.0017	0.0025	0.0028	0.0034	0.0038
L67	0.0000	0.0014	0.0018	0.0025	0.0029	0.0034	0.0038
L68	0.0000	0.0016	0.0021	0.0029	0.0032	0.0038	0.0042
L69	0.0000	0.0019	0.0016	0.0015	0.0016	0.0020	0.0023
L70	0.0000	0.0013	0.0018	0.0025	0.0029	0.0034	0.0038
L71	0.0000	0.0014	0.0017	0.0024	0.0027	0.0033	0.0037
L72	0.0000	0.0011	0.0016	0.0024	0.0028	0.0033	0.0038
L73	0.0000	0.0011	0.0016	0.0024	0.0028	0.0033	0.0038
L74	0.0000	0.0009	0.0013	0.0021	0.0025	0.0030	0.0035
L75	0.0000	0.0015	0.0020	0.0027	0.0031	0.0036	0.0041
AV	0.0000	0.0013	0.0017	0.0023	0.0026	0.0032	0.0036
MIN	0.0000	0.0006	0.0010	0.0015	0.0016	0.0020	0.0023
MAX	0.0000	0.0019	0.0021	0.0029	0.0033	0.0038	0.0042
STDEV	0.0000	0.0003	0.0003	0.0004	0.0005	0.0005	0.0005
N	25	25	25	25	25	25	25

7 – Summary

Table 1: Report at each LM-80 Test Condition							
Description of LED Light Source Tested (manufacturer, model, catalog number)		Test Condition 1 - 55°C Case Temp		Test Condition 2 - 85°C Case Temp		Test Condition 3 - 105°C Case Temp	
Sample size	25	Sample size	25	Sample size	25	Sample size	25
Number of failures	0	Number of failures	0	Number of failures	0	Number of failures	0
DUT drive current used in the test (mA)	150	DUT drive current used in the test (mA)	150	DUT drive current used in the test (mA)	150	DUT drive current used in the test (mA)	150
Test duration (hours)	6,000	Test duration (hours)	6,000	Test duration (hours)	6,000	Test duration (hours)	6,000
Test duration used for projection (hour to hour)	1,000 - 6,000	Test duration used for projection (hour to hour)	1,000 - 6,000	Test duration used for projection (hour to hour)	1,000 - 6,000	Test duration used for projection (hour to hour)	1,000 - 6,000
Tested case temperature (°C)	55	Tested case temperature (°C)	85	Tested case temperature (°C)	105	Tested case temperature (°C)	105
α	5.250E-06	α	6.759E-06	α	1.088E-05	α	1.088E-05
B	1.004	B	1.006	B	1.006	B	1.006
Reported L70(6k)	>36000	Reported L70(6k)	>36000	Reported L70(6k)	>36000	Reported L70(6k)	33,000

Lumen Maintenance

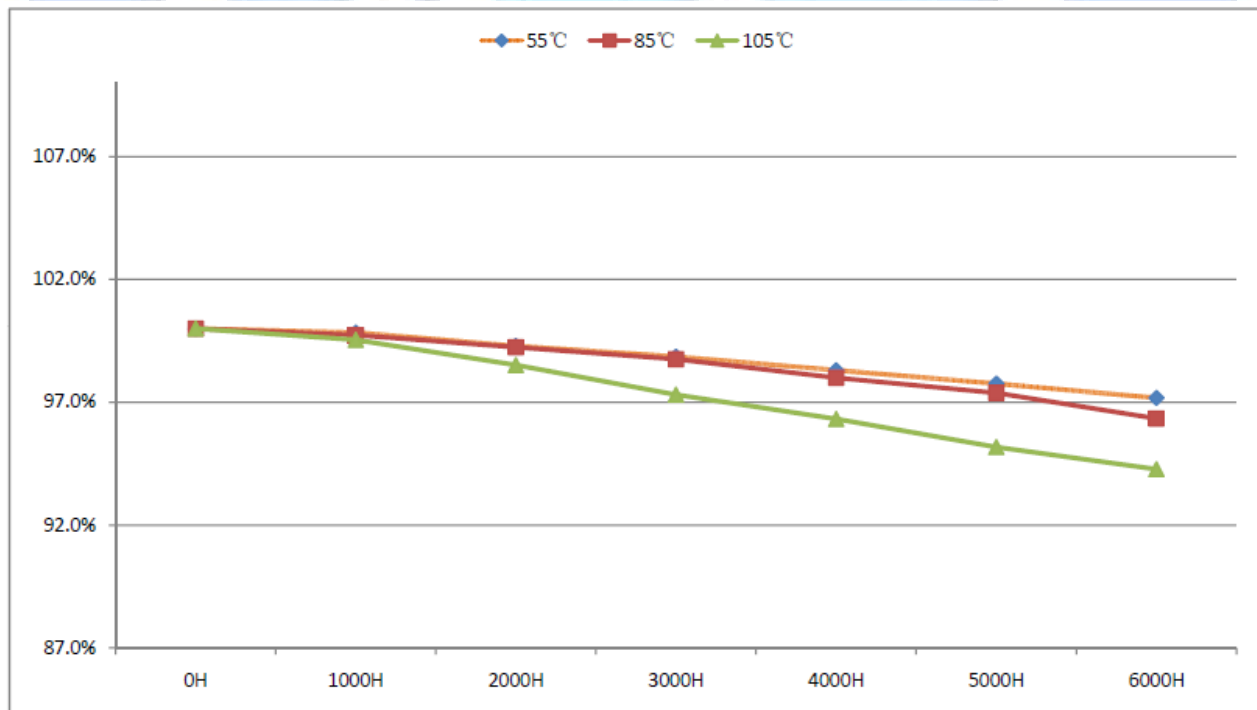

Color Maintenance

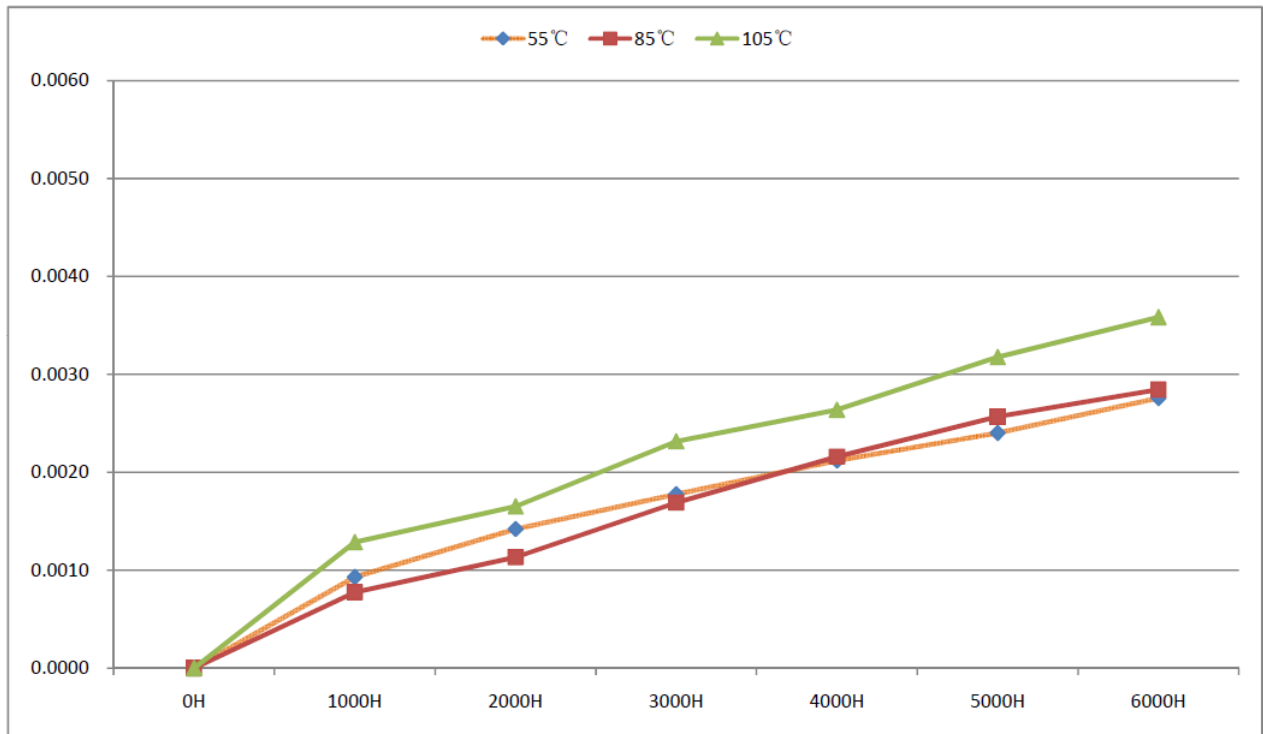

8 – EUT Photos

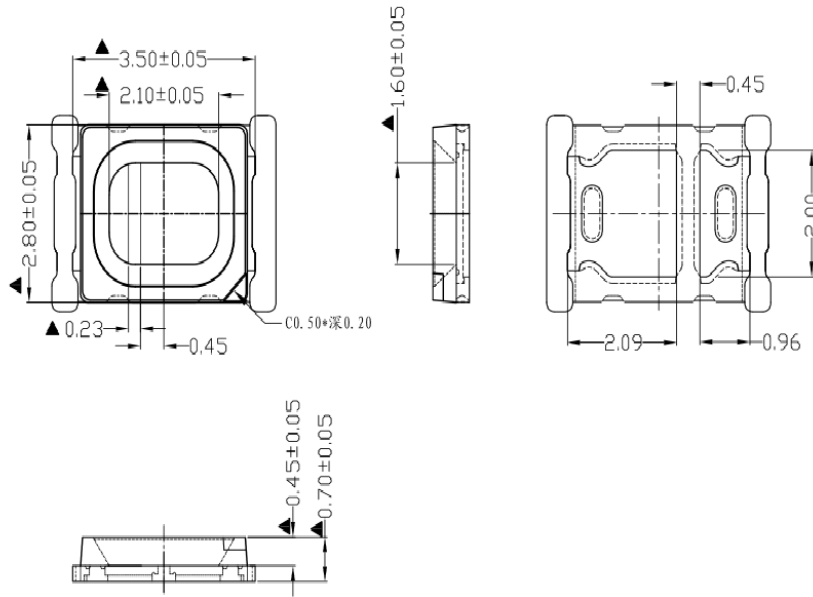

9 -TMP

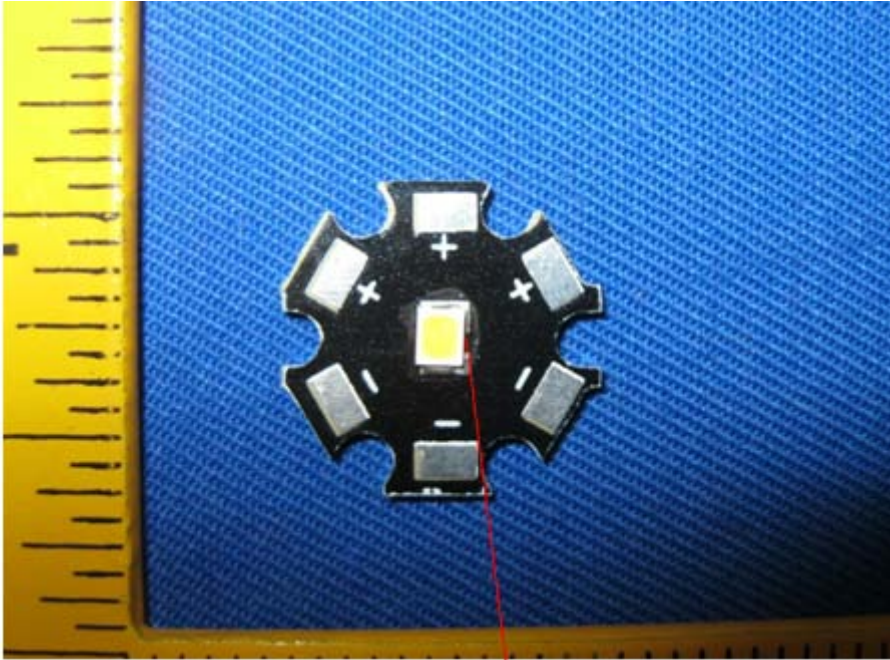

↑
↑
↑
↑

TMP